

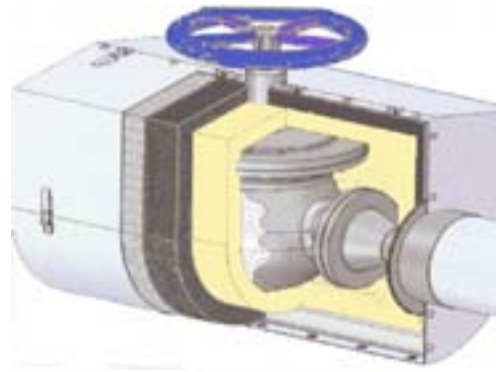

# Handi-Foam

*High density 40-45 kg/m<sup>3</sup>*



## Two Component Polyurethane Foam

- Withstands temperatures between -156°C to +115°C.
- Ideal for cold - industrial insulation applications. (insulating of valves / valve- & flange boxes)
- Fire resistance: B2 (DIN 4102-1) classified.
- User-friendly and “Ready-to-Use” systems.
- Adds an exceptional structural support.
- Environmentally friendly – contains no HCFC’s and CFC’s.



## HANDI-FOAM high density

**Handi-Foam high density** is a portable Two-Component Polyurethane Foam system specially designed for filling / insulating valves (valve- & flange boxes). **Handi-Foam high density** foam has a approx. 95 % closed cell structure and withstands exceptional low temperatures (-156°C). To dismantle the valve- or flange box, a release agent (e.g. lubricant, plastic, grease) has to be applied on the inside of the Aluminium / Stainless Steel construction. This will have a negative influence on the adherence. Cured foam is resistant to moisture, insulates, deadens sounds, adds structural support, provides a continuous air-barrier, fills and seals various size voids. An extra vapour barrier has to be applied on top of the **Handi-Foam High Density** in cold / cryogenic applications! The density of **Handi-Foam** will increase when poured into a cavity!



**Handi-Foam** is "E" (EN 13501-1) and "B2" (DIN 4102-1) classified and available in a High Density formulation. Accessories such as the "Gun Hose Assembly" (GHA) and nozzles can be supplied separately.



Optimum application temperature is 24°C (75°F) but may be sprayed onto colder or warmer substrates, with slight effects on the foam characteristics. Cured foam is resistant to heat and cold (-156°C to +115°C), and to aging, but not to UV rays (i.e. sunlight) unless painted, covered or coated. Cured foam is also chemically inert and non-reactive in approved applications. **Handi-Foam** systems are "ready-to-use", require no outside mechanical or electrical power source and can be applied onto any clean and dry surface in any direction. **Handi-Foam** foam is available in various packaging sizes to meet specific job application requirements.

### Technical Data:

	<b>Handi-Foam II-145 High density</b>	<b>Handi-Foam II-425 High density</b>
<b>Density</b> – free spray (ASTM D-1622)	40-45 kg/m <sup>3</sup>	40-45 kg/m <sup>3</sup>
<b>Expanded volume</b>	265 - 300 Litres	890 – 1.000 Litres
<b>Expansion time</b>	30 - 60 sec.	30 – 60 sec.
<b>K-Factor</b> (28 days)	0.023 W/mK	0.023 W/mK
<b>R-Value</b> (28 days)	1.09/inch	1.09/inch
<b>Air Barrier Properties</b> (ASTM E-283)		
@ 300 Pa	0.05 L / s / m <sup>2</sup>	0.05 L / s / m <sup>2</sup>
@ 75 Pa (extrapolated)	0.0125 L / s / m <sup>2</sup>	0.0125 L / s / m <sup>2</sup>
<b>Tensile Strength</b> (ASTM D-1623)	400 kPa (58 psi)	400 kPa (58 psi)
<b>Compressive Strength</b> (ASTM D-1621)		
Parallel @ 10 %	275 kPa (40 psi)	275 kPa (40 psi)
Perpendicular @ 10 %	145 kPa (21 psi)	145 kPa (21 psi)
<b>Dimensional Stability</b> (ASTM D-2126)		
Heat Age 70°C (+158°F)	+2,0 %	+2,0 %
Humid Age 70°C (+158°F), 100% RH	+3,2 %	+3,2 %
Cold Age - 20°C (-4°F)	-0.2 %	-0.2 %

**Important Note:** Use only in well ventilated areas or with certified respiratory protection. Wear impervious gloves, protective glasses and suitable work clothes when using. Read all instructions and safety information (MSDS) prior to use of any product. The product contains no formaldehyde. Cured foam is non-toxic. **KEEP OUT OF REACH OF CHILDREN!**

**Product Storage:** Store in a cool and dry area in the upright position. Do not expose to an open flame or temperatures above 49°C (120°F). Excessive heat can cause premature aging of components resulting in a shorter shelf life. Containers are under pressure. Do not open with force or incinerate even after use.

**Application / Use:** Valves must be in the upright position. Materials are dispensed through hoses and mixed in a disposable nozzle. Once foaming has stopped, the dispensing unit must be reactivated within 30 seconds or a new nozzle must be installed. Fresh Handi-Foam may be applied in several stages to reduce overfilling or void damage to non-rigid, confined cavities. Cured foam can only be removed mechanically.